

教盘号

CAD

会 签

170F-2T SPECIFICATION

MODEL	170F-2T
ENGINE TYPE	SINGLE CYLINDER 4 STROKE
OUTPUT SHAPE TYPE	Q TYPE (BRP:Q6)
CRANK CASE COVER TYPE	BRITISH SYSTEM TYPE (6/16-24UNF)
EMISSION	
BORE×STROKE mm	70×58mm
DISPLACEMENT (ml)	223ml
COMPRESSION RATIO	9.5: 1
NO LOAD SPEED (rpm)	3850±30
MAX OUTPUT (Kw/rpm)	4.8KW/3600rpm
RATED OUTPUT (Kw/rpm)	4.5KW/3600rpm
MAX TORQUE (N.m/rpm)	13.5 N.m/2500rpm
IDEL SPEED (r/min)	1800±150
START TYPE	RECOIL START
IGNITION TYPE	TCI
FILTER ELEMENT	foam and paper filter
FUEL TANK VOLUME (L)	4.0L
FUEL CONSUMPTION (g/kw.h)	374g/Kw.h
ENGINE OIL VOLUME (L)	0.6L
NET WEIGHT (kg)	16 kg
PACKAGE DIMENSION (mm)	416×380×380(mm)

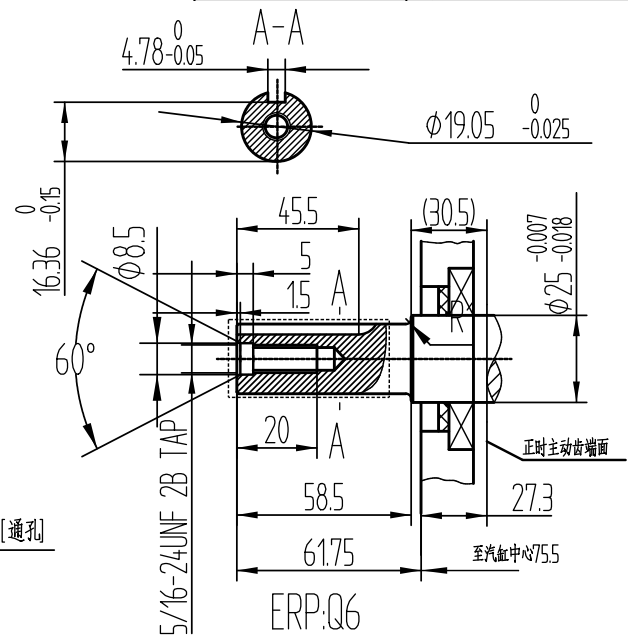
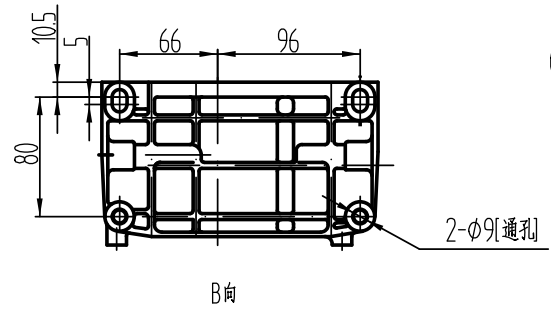
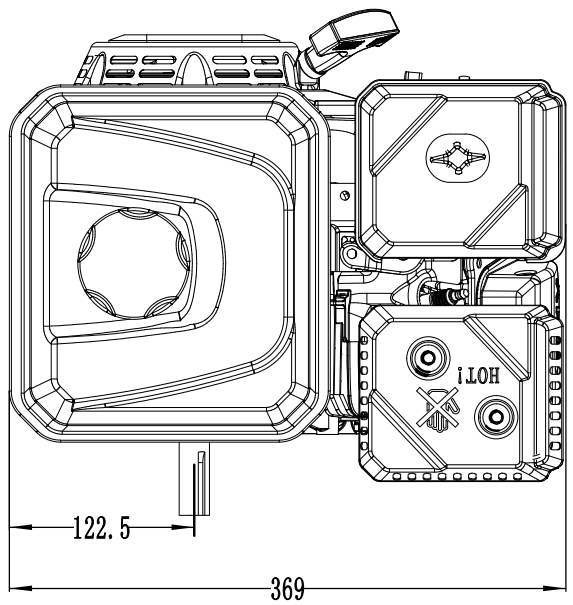
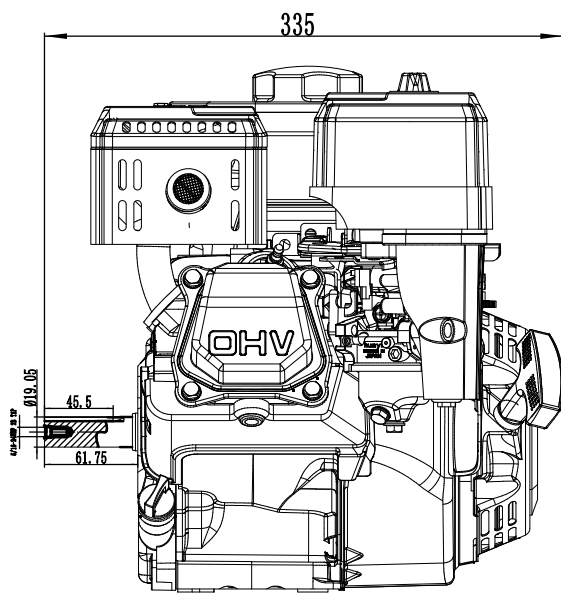
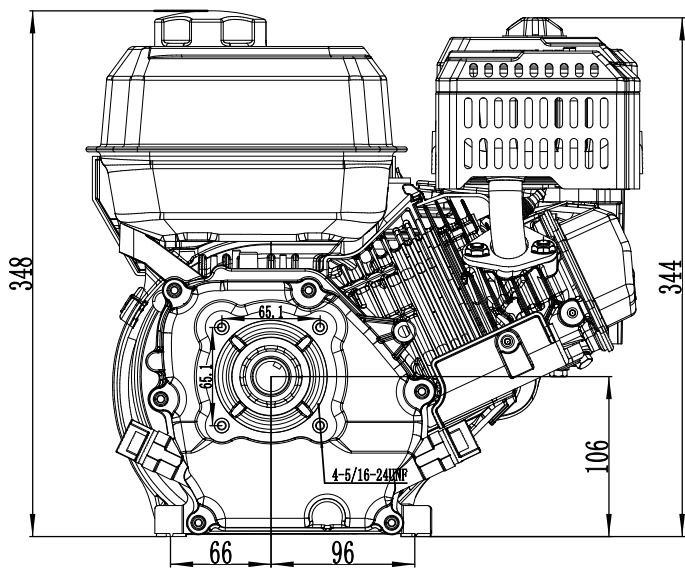

				170F-2T	10000
标记处数	文件号	签字	日期	所属装配件号	
设计				图样标记	
校核				质量	比例
审查				S	1:1
工艺				共 1 张 第 1 张	
标准化				重庆力帆内燃机有限公司	
审定					
批准					

170F-2T
整机外形尺寸图